

L05-6675-325-12

13 SEPTEMBER 1983

TOPOGRAPHIC SUPPORT SYSTEM

SYNTHESIS SECTION

MODEL ADC-TSS-14

NSN: 6675-01-105-5763

Reference TM 5-6675-325-14 and C9100-IL

Intervals and the related manhour times are based on normal operation. The manhour time specified is the time you need to do all the services prescribed for a particular interval. Decrease the interval and lubricate more frequently if your lubricants have been contaminated or you are operating under adverse conditions, including longer-than-usual operating hours. The intervals between lubrications may be extended during periods of low activity, but only if adequate preser-

vation precautions have been taken. The lowest level of maintenance authorized to lubricate a point is indicated by one of the following symbols: Operator/Crew (C) and Organizational Maintenance (O). Clean all fittings, plugs, and caps before removal and/or lubrication. Remove all excess oil or grease after lubrication. If possible, exercise moving parts to distribute lubricant evenly. Lubricate all oil can points after washing or fording.

LUBRICANT ● INTERVAL

INTERVAL ● LUBRICANT

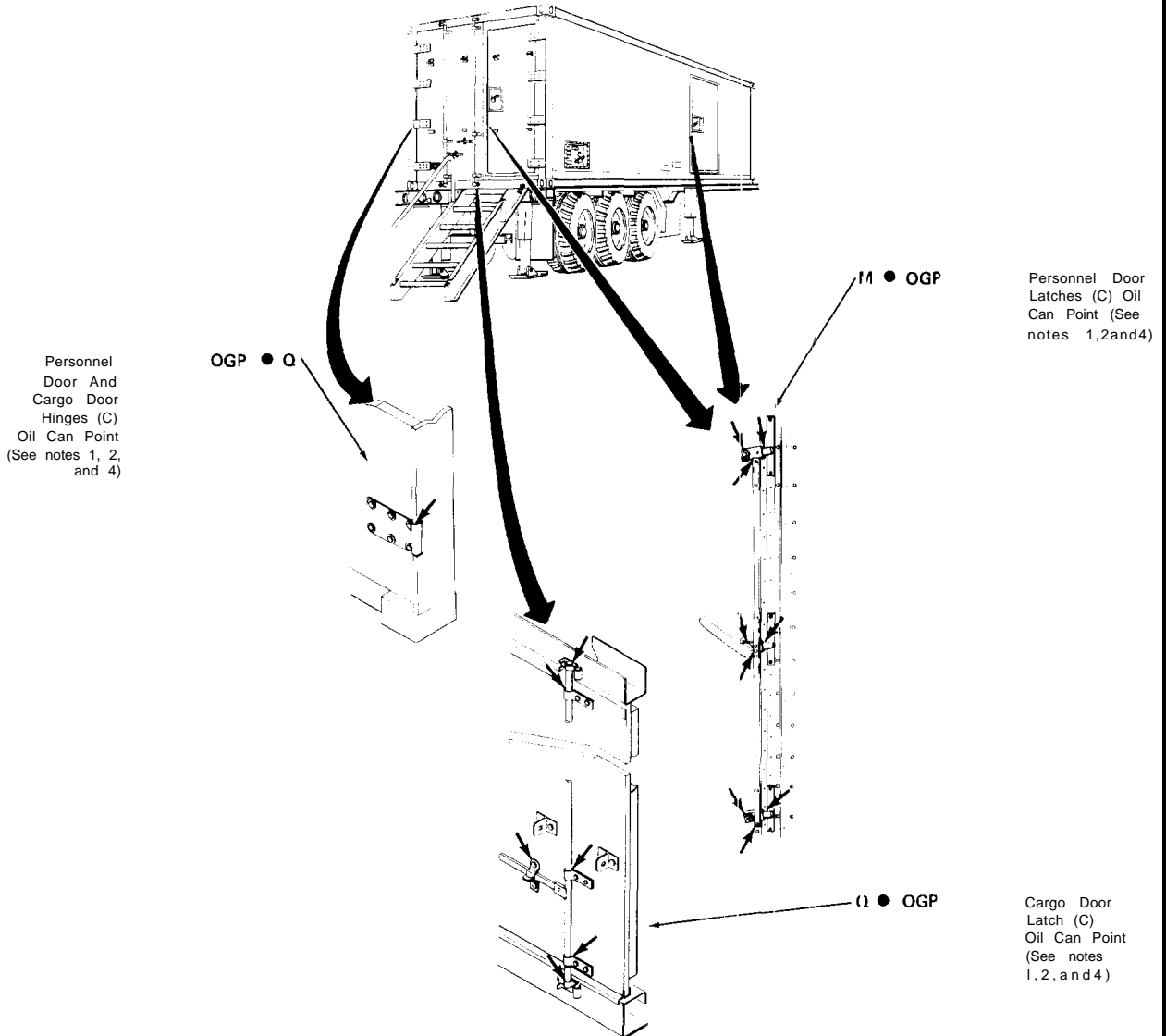

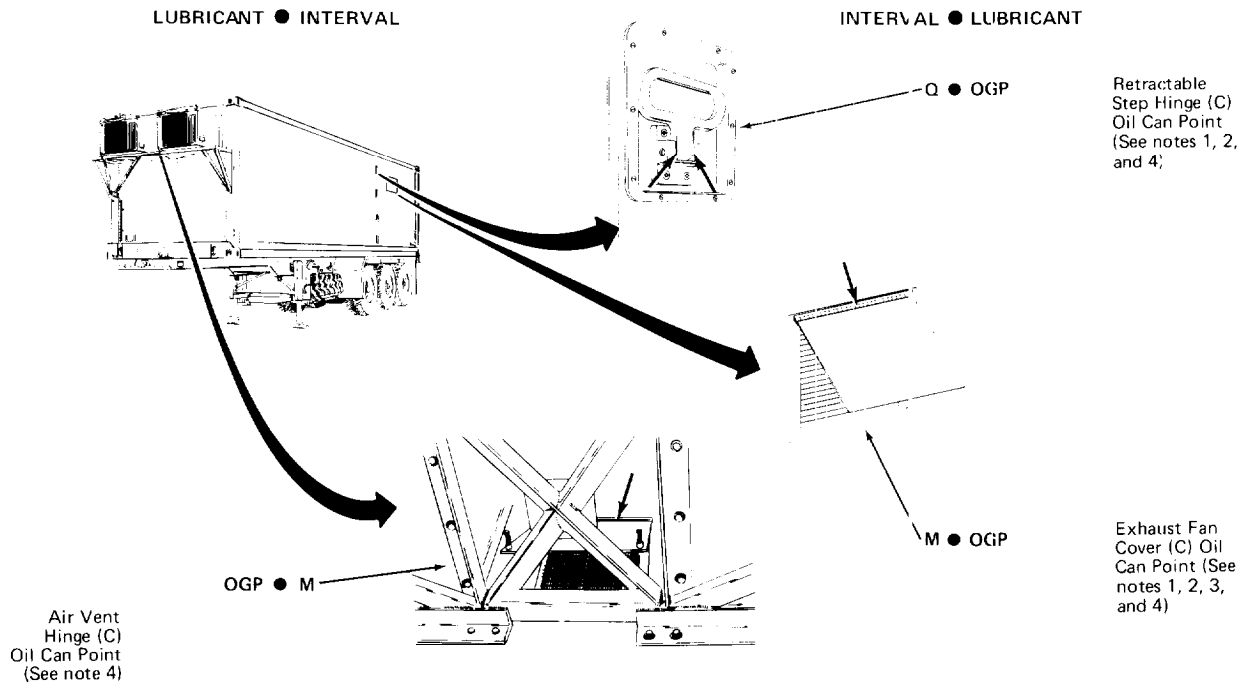

TOTAL MAN - HR		TOTAL MAN HR	
INTERVAL	MAN - HR	INTERVAL	MAN - HR
M	0.3	Q	0.6

KEY

LUBRICANTS	EXPECTED TEMPERATURES	INTERVALS
OGP (MIL-L-7870) LUBRICATING OIL, GENERAL PURPOSE, LOW TEMPERATURE PERSONNEL DOOR AND CARGO DOOR HINGES PERSONNEL DOOR LATCHES CARGO DOOR LATCHES RETRACTABLE STEP HINGE EXHAUST FAN COVER AIR VENT HINGE	All Temperatures	M MONTHLY Q QUARTERLY

NOTES

- Before lubricating wipe all points free of dirt, grease or dust.
- Wipe all surplus oil from surfaces after lubrication.
- When lubricating hinges, be sure oil covers entire length of hinge.
- OIL CAN POINTS.** In accordance with the intervals listed in this Lubrication Order, lubricate the Door Hinges and Latches, Step Hinges, Air Vent Hinge and Exhaust Fan Cover Hinge with OGP.

Copy of this Lubrication Order will remain with the equipment at all times; instruction contained herein are mandatory.

By Order of the Secretary of the Army:

JOHN A. WICKHAM, JR.
General, United States Army
Chief of Staff

Official:

ROBERT M. JOYCE
Major General, United States Army
The Adjutant General

DISTRIBUTION:

To be distributed in accordance with DA Form 12-25A, Operator maintenance requirements for Mapping.